

A T E L I E R



OLDLINE
LEGNO DA VIVERE

SAPORE ITALIANO - *italian flavor*

IN-

CANTO

INDICE - Contents

3
L'AZIENDA
Our Company

4
LA NOSTRA FILOSOFIA
Our philosophy

4
100% MADE IN ITALY
100% Made in Italy

5
L'ARTIGIANALITÀ
Craftsmanship

5
LA SOSTENIBILITÀ
Sustainability



L'AZIENDA *our company*



Old Line è un'azienda che affonda le sue radici nella tradizione ebanistica veneta. Nata 40 anni fa da artigiani accomunati dall'amore per la lavorazione del legno, oggi è un'industria strutturata e punto di riferimento nel mondo della cucina tradizionale. Con alle spalle un importante bagaglio di esperienza nel settore, oggi la seconda generazione continua ad immettere sul mercato prodotti dal design classico, contestualizzati in una modernità compositiva per l'arredo di spazi esclusivi. L'utilizzo di materiali pregiati, la cura dei dettagli e di soluzioni tecniche innovative, sono la chiave per la realizzazione di cucine accoglienti, ospitali, funzionali e di raffinata eleganza.

Old Line's roots are deeply embedded in the cabinet-making tradition of the Veneto region in Italy. Established 40 years ago by artisans who shared a love for timber, ours is now a well-organised company that others in the world of traditional kitchens look up to. Thanks to a heritage of great experience in the sector, the second generation at the helm of the company is still making classic furniture for the market, now contextualised in modern layouts to furnish exclusive spaces. Prized materials, care to detail and innovative technical solutions are the keys to building inviting, cosy, functional and exquisitely elegant kitchens.

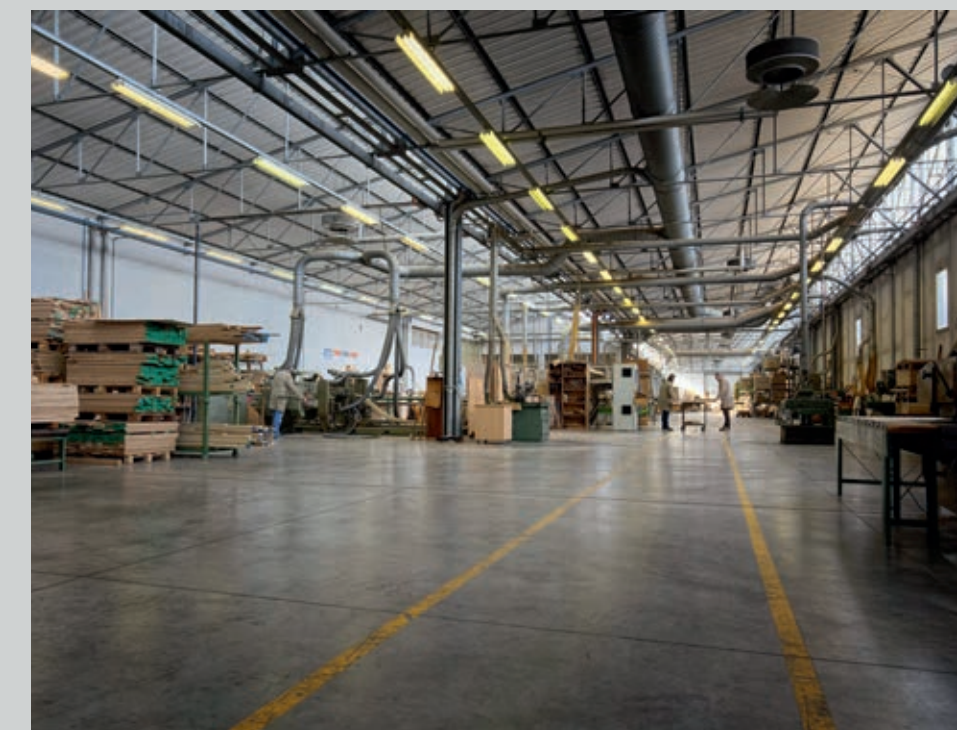

LA NOSTRA FILOSOFIA *our philosophy*

Recupero e valorizzazione della tradizione.

Questi sono i cardini attorno ai quali ruota la nostra filosofia aziendale. Old Line, infatti, proprio perché nata come piccola realtà artigianale, non ha mai scordato le proprie origini. A quest'ultima continua infatti ad attingere, in un continuo processo innovativo dove la tradizione si sposa con le più moderne tecniche produttive.

Attraverso la valorizzazione del know-how tramandato di padre in figlio, l'azienda è oggi espressione di un'imprenditorialità sostenuta da una genuina passione per il legno e per il design.

To bring back and enhance tradition.

This is the cornerstone of our company philosophy.

In fact, since we started as a small, woodworking business, we have never forgotten our origins and we keep drawing from them, in an ongoing process of innovation in which tradition is paired with the most modern production technologies. By making the most of the know-how handed down from father to son, today our company's business skills are backed up by an authentic passion for wood and design.



100% MADE IN ITALY *100% made in italy*

Per Old Line il Made in Italy è un'imprescindibile caratteristica dei propri prodotti. Ogni componente viene infatti lavorato all'interno dell'azienda, dal più semplice al più complesso.

Solo così è possibile garantire l'intera filiera produttiva, con un costante e capillare controllo della qualità dei materiali e delle finiture, per ottenere mobili di eccellenza caratterizzati da un inconfondibile stile italiano.

The furniture produced by us at Old Line is entirely Made in Italy: an intrinsic and indispensable feature of all our products. Each part, no matter how simple or complex, is made on our premises. We know no other way to guarantee the entire production chain, by means of thorough, ongoing quality controls carried out on materials and finishes to obtain top-quality furniture marked by the unmistakable Italian style.

L'ARTIGIANALITÀ *craftsmanship*

Artigianalità, ovvero saper costruire con amore, come un tempo. Per Old Line questo aspetto fa parte del dna aziendale perché le nostre origini sono proprio quelle di artigiani del legno.

Scegliamo con cura i materiali, selezionandoli e testandoli, consapevoli che la bontà della materia prima è fondamentale per l'ottenimento di prodotti di alta qualità. Nelle lavorazioni impieghiamo tutta la nostra competenza, curando ogni dettaglio, forti di una consolidata esperienza ebanistica.

Craftsmanship means knowing how to make things with love and care, just like they used to be in the past. Since we started out as cabinet makers, this is still an intrinsic part of our makeup. We choose our materials carefully, selecting them and testing them, well aware that excellent raw materials are essential to make a top-quality product. We invest all our skills in crafting our furniture, taking care of every detail, backed up by our sound experience as cabinet makers.



LA SOSTENIBILITÀ *sustainability*

La salvaguardia dell'ambiente è da sempre un aspetto basilare per Old Line.

I nostri processi produttivi vengono continuamente ottimizzati, controllati ed aggiornati.

L'utilizzo di energia elettrica autoprodotta copre fino al 50% del fabbisogno energetico, prezioso contributo ad un processo virtuoso di effettiva eco-sostenibilità.

For us at Old Line, environmental awareness is essential. Our production processes are continuously optimised, checked and updated. Up to 50% of our electricity requirements are self-produced: an important contribution to a virtuous process of authentic eco-sustainability.

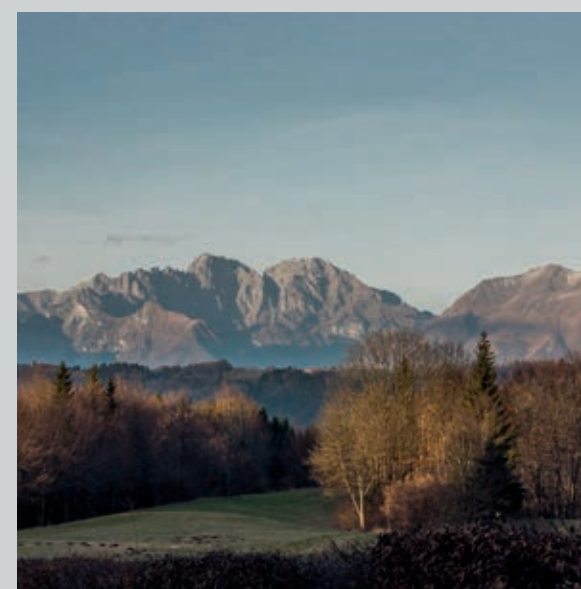



LE PROPOSTE - *the proposal*

8
COMPOSIZIONE 1
Arrangement 1

28
COMPOSIZIONE 2
Arrangement 2

7

48
COMPOSIZIONE 3
Arrangement 3



 **COMPOSIZIONE 1**
ARRANGEMENT 1

Anta: modello Iris e Light
Finitura: Ebano Structur e alluminio Bronzato
Top Pietra Grey Seamless

Doors: Iris and Light model
Finishes: Structur ebony and Bronzato
aluminium
Grey seamless stone top







Incanto è espressione di una bellezza ricercata e costruita con attenzione, un modello che sposa funzionalità ad un vero e proprio stile architettonico. Incanto lascia il segno, stupisce e fa del lusso il suo segno distintivo.

Incanto expresses refined beauty crafted with care, a model that pairs functionality with an authentically architectural style. Incanto is a collection whose hallmark is luxury, that doesn't go unnoticed and takes your breath away.



In questa cucina legno e metallo si sottopongono ad una rilettura contemporanea, capace di trasformare i volumi. Razionalità, ricerca ed ergonomia scandiscono in questo progetto il ritmo dell'eleganza.

In this kitchen, wood and metal are utilised in a contemporary key and are capable of transforming volumes. In this configuration, rationality, research and ergonomics play out elegance.



Le colonne a tutta altezza con le innovative ante in alluminio alveolare, solide e leggere, sfiorano il soffitto diventando parte integrante di un ambiente ad alto impatto estetico.

Full-height tall units - featuring innovative, sturdy and lightweight aluminium honeycomb doors - reach up to the ceiling and become an integral part of the room, creating a strong aesthetic impact.







La vetrina a doppia altezza è realizzata in essenza scura, con ante vetro ed elemento centrale in finitura laccato Rugiada che esalta gli eleganti porta bottiglie.

The dual-height glass cabinet is made of dark wood and features glass doors while the inside of the central section is in Rugiada lacquer that sets off the elegant bottle-racks.





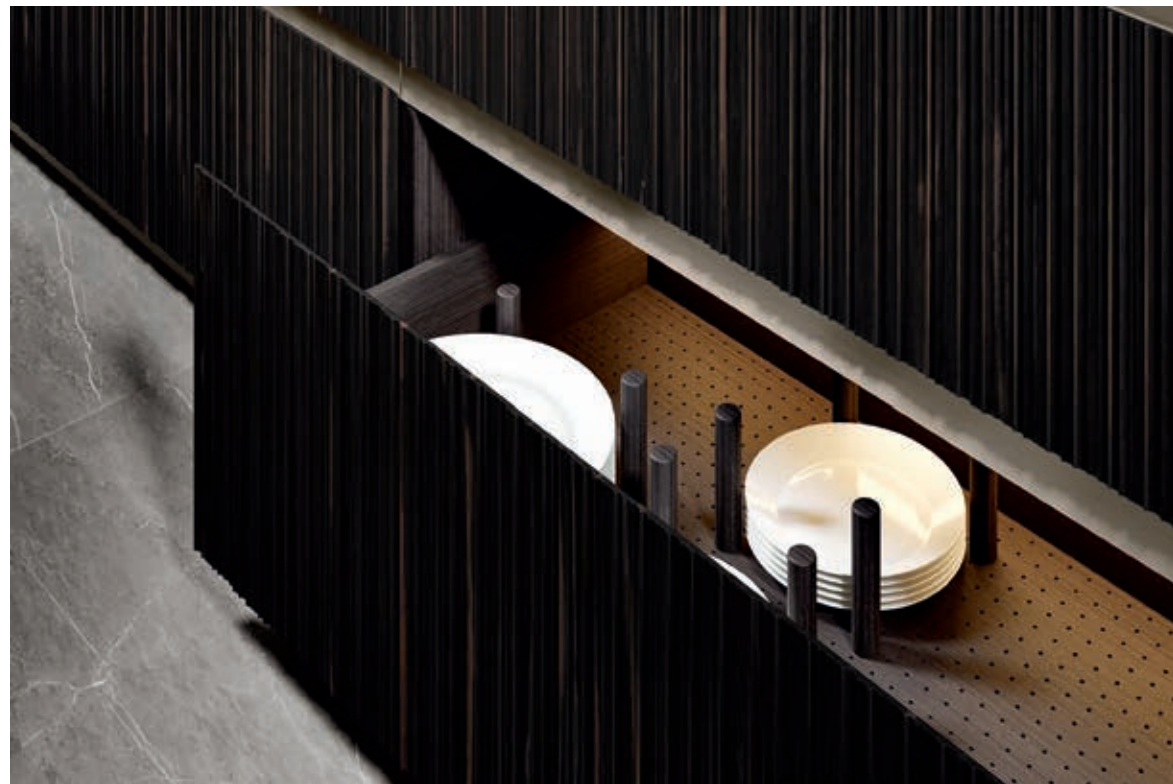

Gola a 33°
33° grip recess

Maniglia
Handle

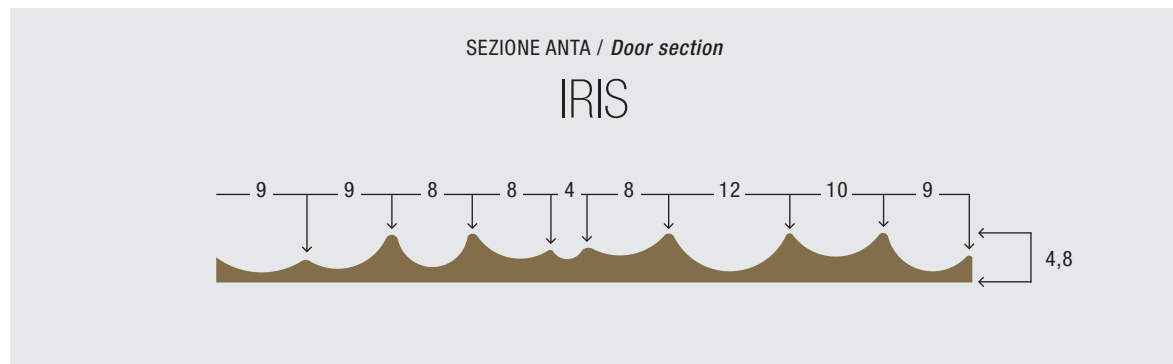



SCHEDA TECNICA
COMPOSIZIONE
Technical data sheet for arrangements

ANTA
Door



IRIS

ANTA
Door



LIGHT

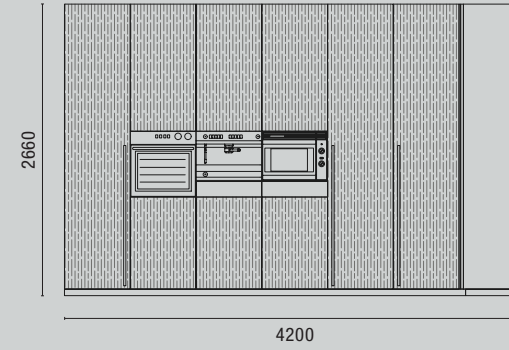

PROSPETTO A-A
Front view A-A

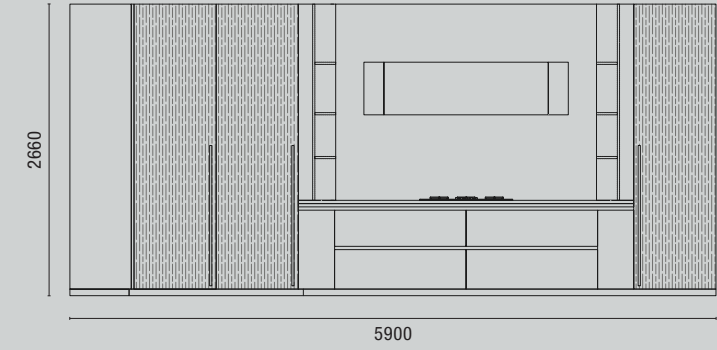

PROSPETTO B-B
Front view B-B

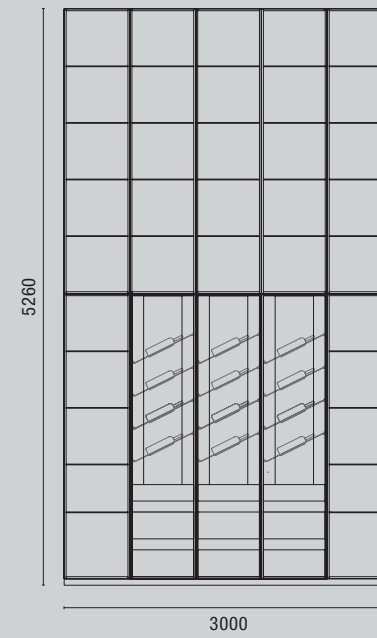

PROSPETTO C-C
Front view C-C

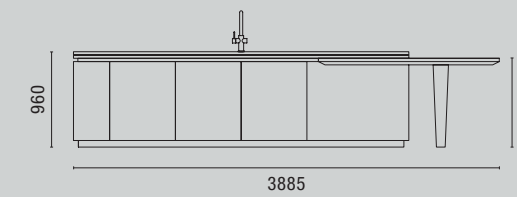

PROSPETTO D-D
Front view D-D

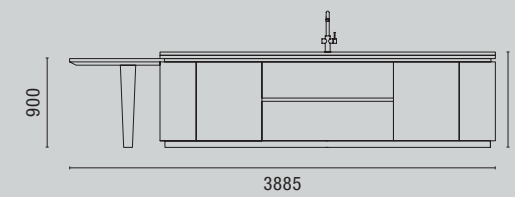

PROSPETTO E-E
Front view E-E

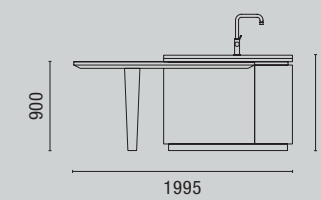

PROSPETTO F-F
Front view F-F

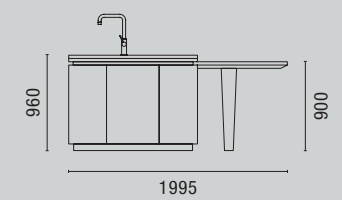

PROSPETTO G-G
Front view G-G

VISTA IN PIANTA
Top view

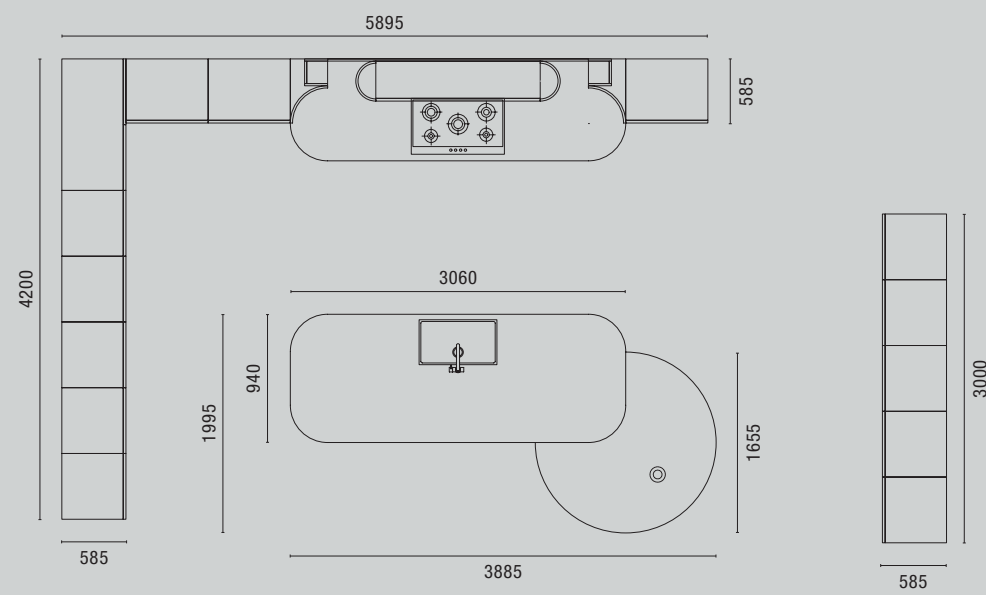

FINITURE UTILIZZATE
Finishes used

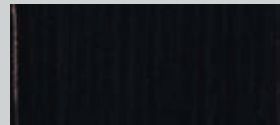

Ebano
Ebony



Pietra Grey_SEAMLESS
Grey_SEAMLESS stone

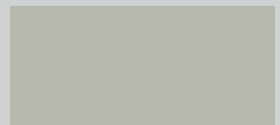

Rugiada - Laccato NCS 2502Y
Rugiada - NCS 2502Y lacquer



Bronzato
Bronzato



**COMPOSIZIONE 2
ARRANGEMENT 2**

Anta: modello Iris e modello Alpha
Finitura: Rovere Incanto e laccato opaco
 Carbone NCS 7502-Y
 Top Pietra Grey Seamless

Doors: modello Iris e modello Alpha
Finishes: Rovere Incanto e laccato opaco
 Carbone NCS 7502-Y
 Grey seamless stone top



La scelta del rovere chiaro per Incanto esprime l'eleganza italiana, grazie alla finitura delicata e luminosa di questa essenza pregiata. L'ambiente diventa sofisticato e accogliente, con un tocco moderno. Incanto diventa così un'opera d'arte che celebra l'eccellenza del design italiano.

The choice of light oak for Incanto expresses Italian elegance, thanks to the delicate and luminous finish of this precious wood. The environment becomes sophisticated and welcoming, with a modern touch. Incanto becomes an artwork that celebrates the excellence of Italian design.





La scelta di posizionare due isole da cucina in modo speculare, una di fronte all'altra, è un'idea audace e funzionale che aggiunge un tocco di raffinatezza alla cucina moderna. Il piano di lavoro in Pietra Grey Seamless, dalla forma a saponetta e con bordo salvagoccia, aggiunge un tocco di eleganza e praticità alla stanza.

The choice of positioning two kitchen islands in a specular way, facing each other, is a bold and functional idea that adds a touch of sophistication to modern kitchens. The Pietra Grey Seamless worktop, with its soap-shaped form and drip edge, adds elegance and practicality to the room.





I vassoi in legno massello con incastro a coda di rondine che scorrono su guide per un'estrazione quasi totale sono un esempio di funzionalità oltre che di artigianalità.

The solid wood trays with dovetail joints that slide on guides for almost full extension are an example of both functionality and craftsmanship.







La vetrina a tutta altezza è un elemento di design d'impatto, capace di attirare l'attenzione e conferire personalità all'ambiente circostante. Le due ante centrali, completamente rientranti e realizzate in elegante laccato opaco Carbone, celano la possibilità di accedere ad uno spazio adiacente

The full-height showcase is a design element of great impact, capable of capturing attention and adding personality to the surrounding environment. The two central doors, fully retractable and elegantly finished in matte Carbone lacquer, conceal the possibility of accessing an adjacent space.







La vetrina internamente illuminata è dotata di accessori di alta qualità, come griglie porta bottiglie e vassoi in legno massello, personalizzabili ed estraibili.

The internally illuminated showcase is equipped with high-quality accessories, such as bottle racks and customizable and removable solid wood trays.





**SCHEMA TECNICA
COMPOSIZIONE**
*Technical data sheet for
arrangements*

ANTA
Door



IRIS

ANTA
Door



ALPHA

FINITURE UTILIZZATE
Finishes used

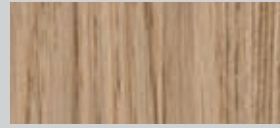

Rovere Incanto
Incanto Oak



Pietra Grey_SEAMLESS
Grey_SEAMLESS stone

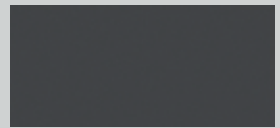

Carbone - Laccato NCS 7502-Y
Carbone - NCS 7502-Y lacquer

VISTA IN PIANTA
Top view

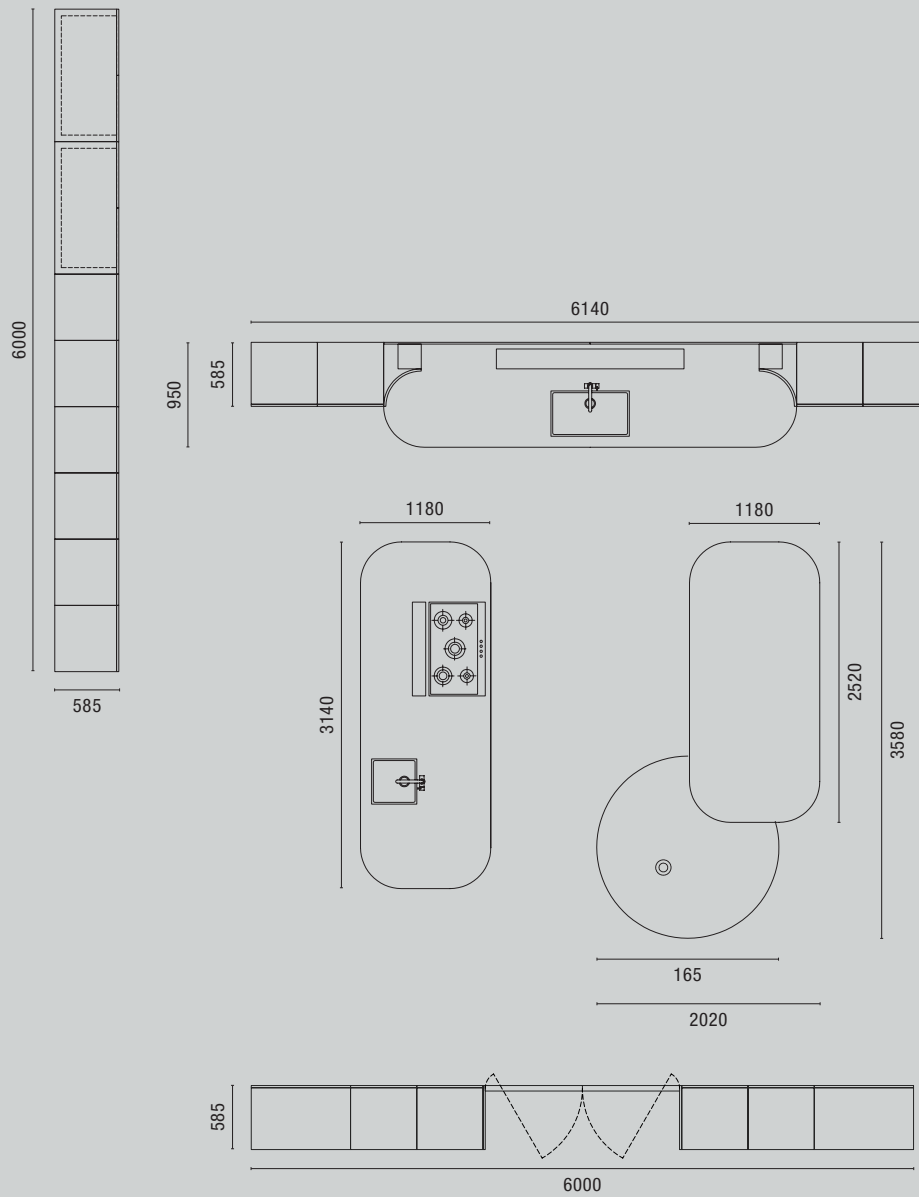

PROSPETTO A-A
Front view A-A

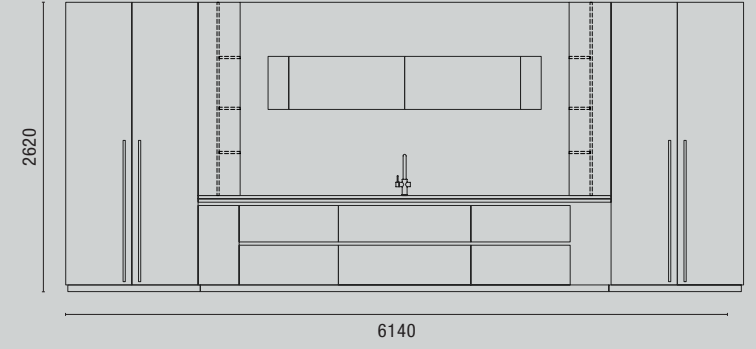

PROSPETTO B-B
Front view B-B

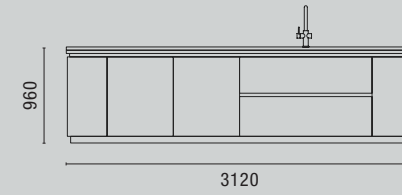

PROSPETTO C-C
Front view C-C

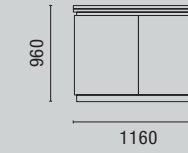

PROSPETTO D-D
Front view D-D

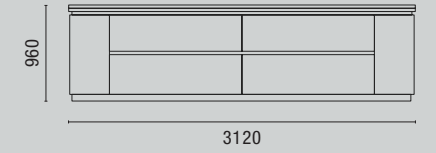

PROSPETTO E-E
Front view E-E

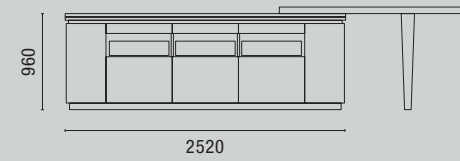

PROSPETTO F-F
Front view F-F

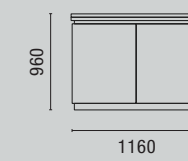

PROSPETTO G-G
Front view G-G

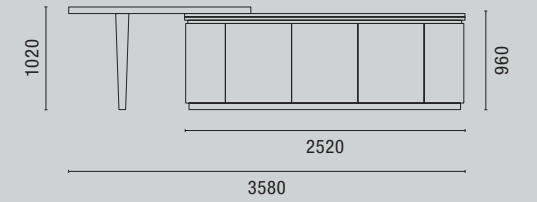

PROSPETTO F-F
Front view F-F

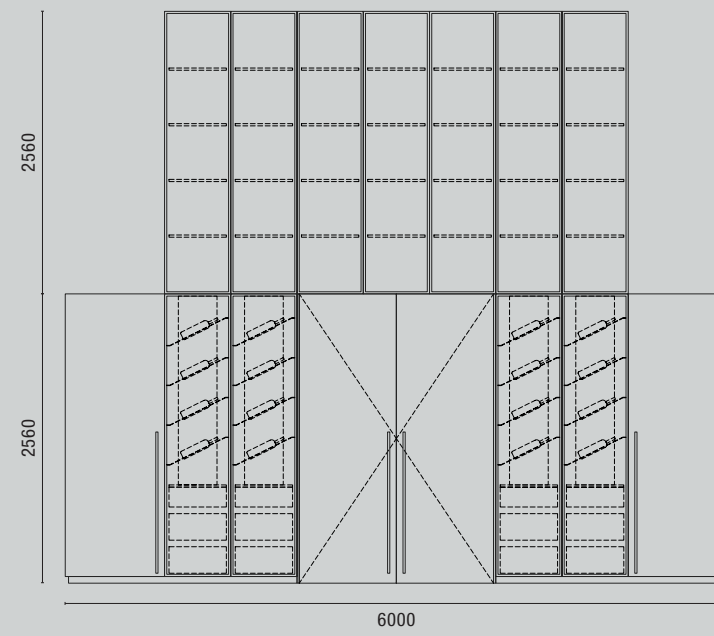

PROSPETTO I-I
Front view I-I



 **COMPOSIZIONE 3**
ARRANGEMENT 3

Anta: modello Iris e modello Alpha
Finitura: Rovere Incanto e laccato opaco Perla
NCS 1500-N
Top Neolith "Retrostone Silk"

Doors: modello Iris e modello Alpha
Finishes: Rovere Incanto e laccato opaco
Perla NCS 1500-N
Neolith "Retrostone Silk" worktop







I due vani laterali aperti, posti a collegamento tra la linearità delle colonne a tutta altezza con ante a vetro e la semicircularità degli angoli della base, costituiscono un punto di raccordo straordinario. Questi spazi aperti sono allo stesso tempo scenografici e funzionali, poiché realizzati con pannelli curvati a semicerchio che utilizzano l'altezza e la profondità del fianco delle colonne per creare idealmente due quinte sulla base operativa.

The two open side compartments, placed as a connection between the linearity of the full-height columns with glass doors and the semicircular shape of the base, constitute an extraordinary junction point. These open spaces are both scenic and functional, as they are made with curved semicircular panels that use the height and depth of the column sides to create two ideal curtains on the operational base.





Le colonne a tutta altezza, con ante in vetro trasparente in finitura canettato, sono dotate di un telaio in metallo bronzato che svolge anche la funzione di maniglia. La lavorazione del vetro crea un suggestivo effetto di "vedo-non-vedo", che alleggerisce e dona ulteriore eleganza alla base operativa.

The columns with transparent glass doors in a ribbed finish feature a bronzed metallic frame that serves as a handle. The glass with this particular finish creates a pleasant see-through effect that lightens and adds further elegance to the work base.







La base contenitore a doppia profondità, realizzata in finitura laccato opaco Perla, fa parte integrante dell'isola e oltre ad assolvere la funzione di spazio contenitivo fa anche da divisorio tra la zona operativa e l'area adiacente destinata al tavolo.

The double-depth storage base, finished in matt Perla lacquer, is an integral part of the island and not only serves as a storage space but also acts as a divider between the working area and the adjacent table area.



Testo finto da fare di una bellezza ricercata e costruita con attenzione, un modello che sposa funzionalità ad un vero e proprio stile architettonico. Incanto lascia il segno, stupisce e fa del lusso il suo segno distintivo.

The doors of the full-height columns, finished in matte Perla lacquer, take advantage of the depth of the columns themselves to almost completely retract and offer a wider and more comfortable use of the internal compartments.



L'attrezzatura interna delle colonne è altamente personalizzabile grazie all'ampia scelta di accessori disponibili.

The internal equipment of the columns is highly customizable thanks to the wide selection of accessories available.





La possibilità di coordinare cucina e zona living sia per quanto riguarda le finiture che per lo stile estetico, permette di creare un flusso armonioso tra gli ambienti.

The possibility to coordinate the kitchen and living area both in terms of finishes and aesthetic style, allows to create a harmonious flow between the environments.







SCHEDA TECNICA
COMPOSIZIONE
Technical data sheet for arrangements

ANTA
Door



IRIS

ANTA
Door



ALPHA

FINITURE UTILIZZATE
Finishes used

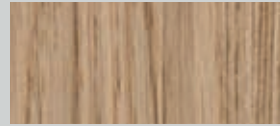

Rovere Incanto
Incanto Oak



Top Neolith
Neolith worktop

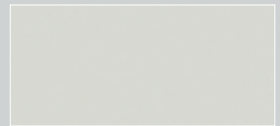

Perla - Laccato NCS 1500-N
Perla - NCS 1500-N lacquer

VISTA IN PIANTA
Top view

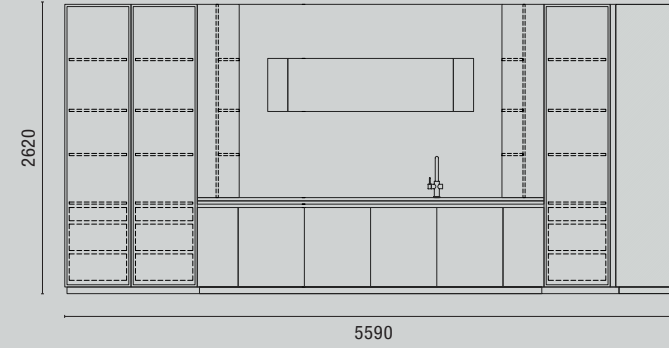
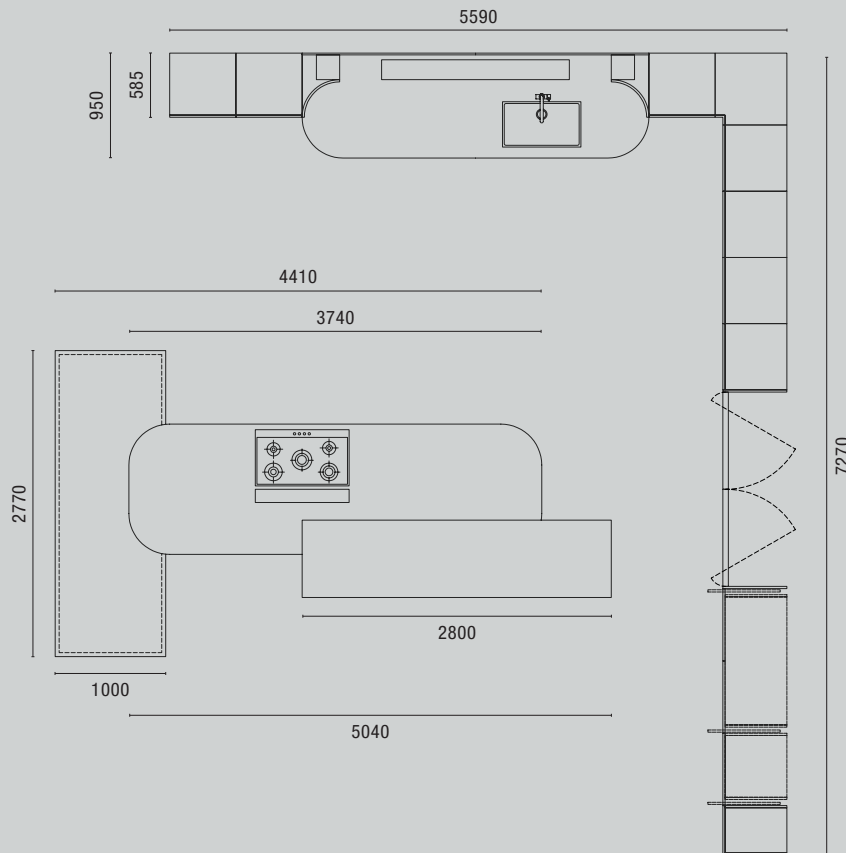

PROSPETTO A-A
Front view A-A

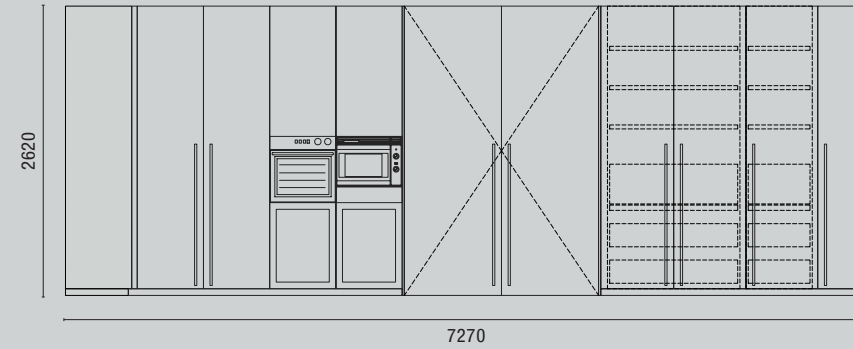

PROSPETTO B-B
Front view B-B

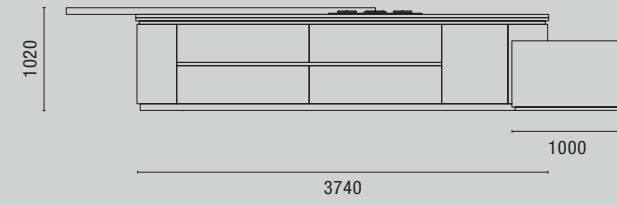

PROSPETTO C-C
Front view C-C

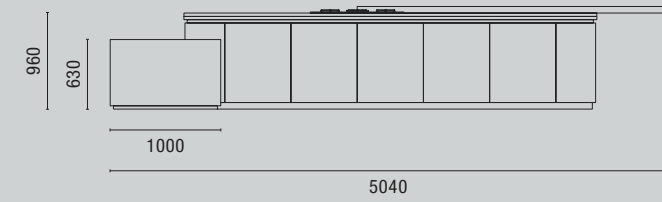

PROSPETTO E-E
Front view E-E

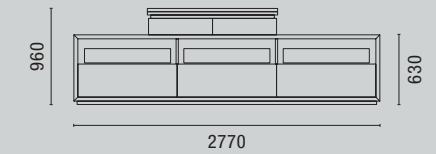

PROSPETTO D-D
Front view D-D

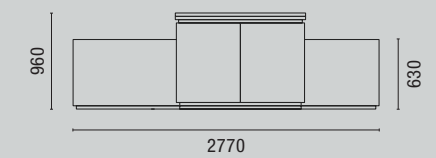

PROSPETTO F-F
Front view F-F

ANTA IRIS
EBANO
IRIS EBONY DOOR

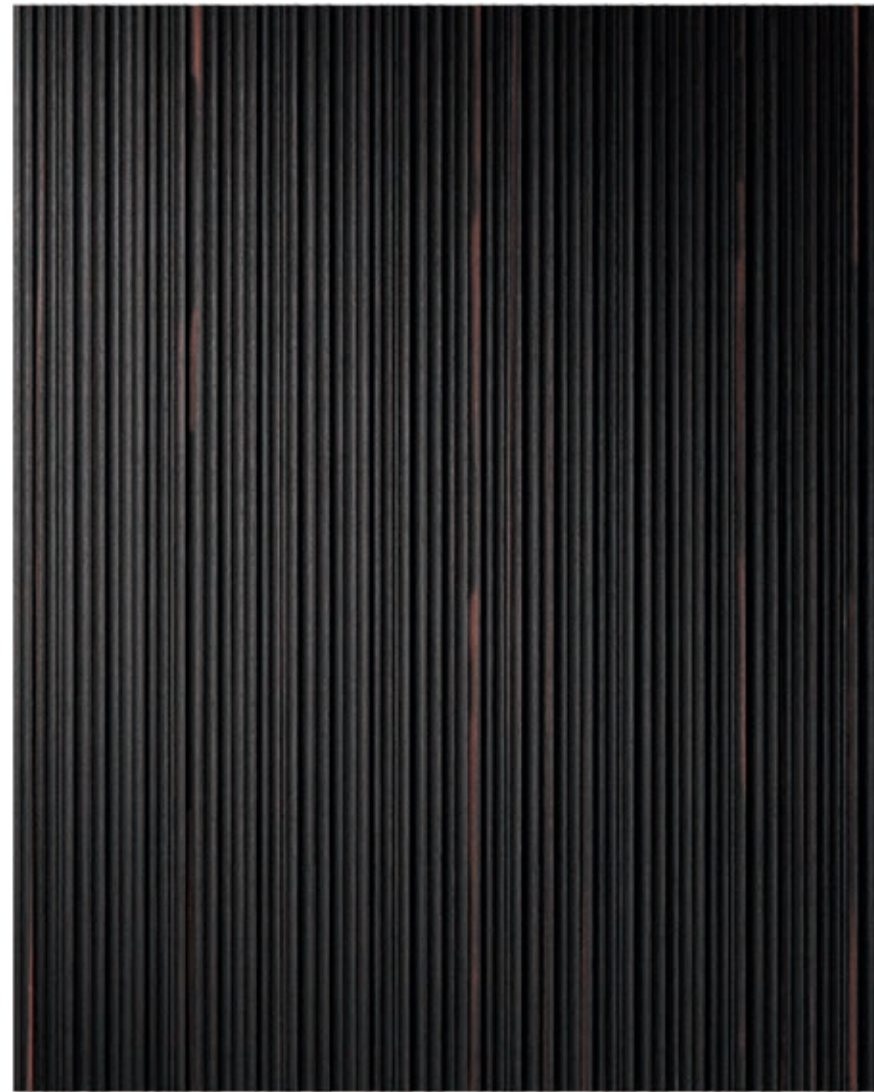
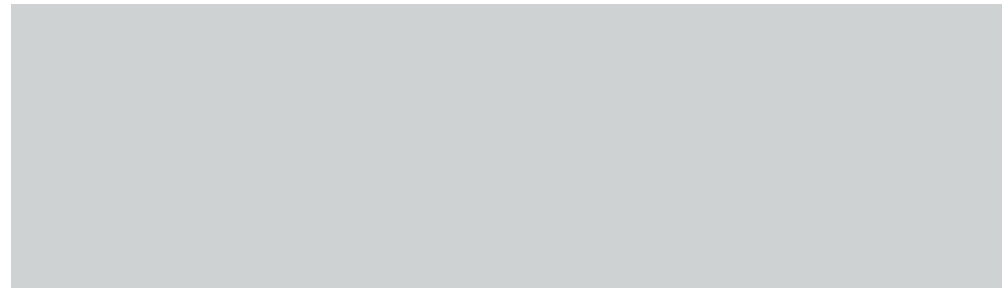

ANTA SPESSORE 25 mm
25 mm thick door

25 mm



ANTA EOS
EBANO
EOS EBONY DOOR

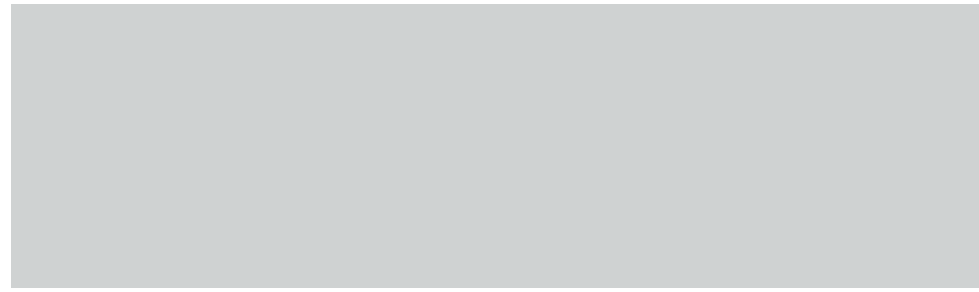

ANTA SPESSORE 25 mm
25 mm thick door

25 mm



ANTA IRIS

ROVERE INCANTO

IRIS INCANTO OAK DOOR

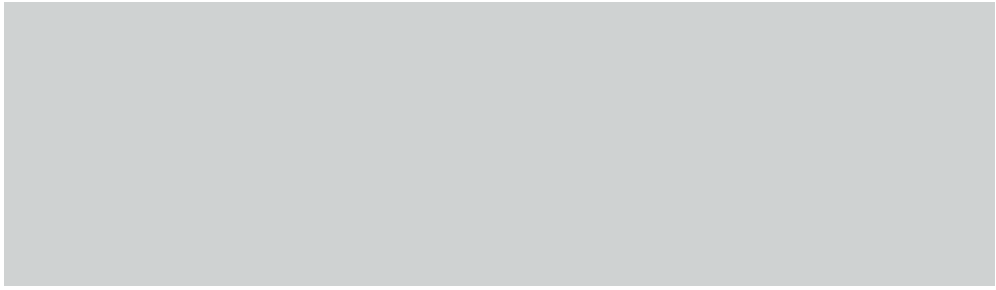

ANTA SPESSORE 25 mm
25 mm thick door

25 mm



ANTA EOS

ROVERE INCANTO

EOS INCANTO OAK DOOR

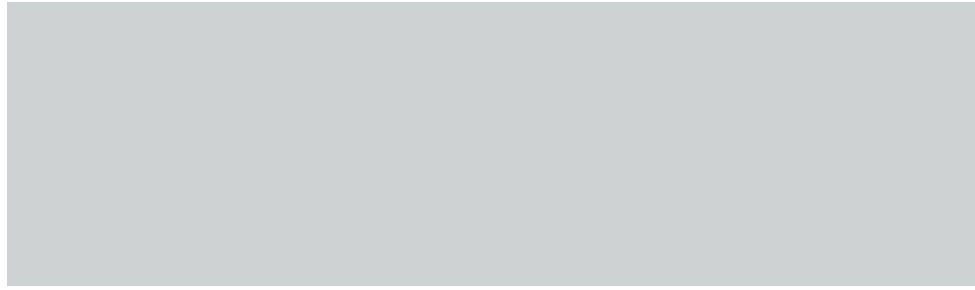

ANTA SPESSORE 25 mm
25 mm thick door

25 mm



ANTA ALPHA

ALPHA DOOR

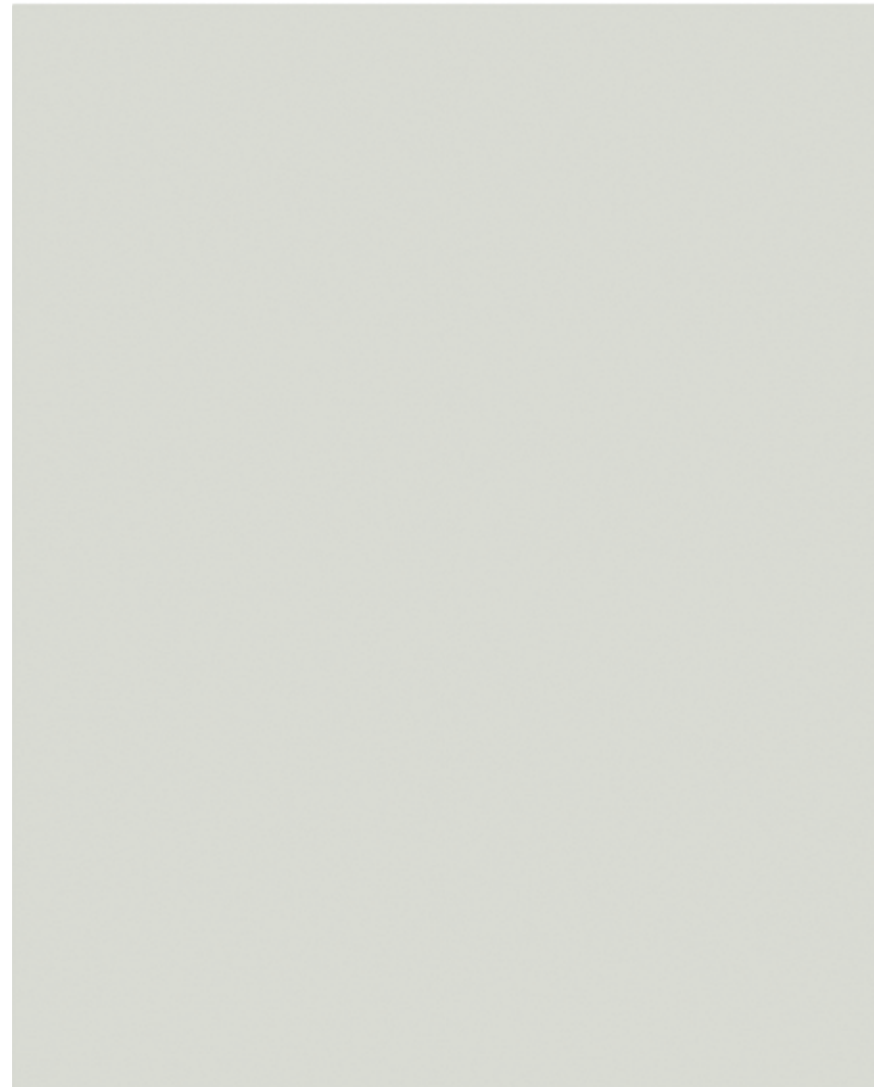
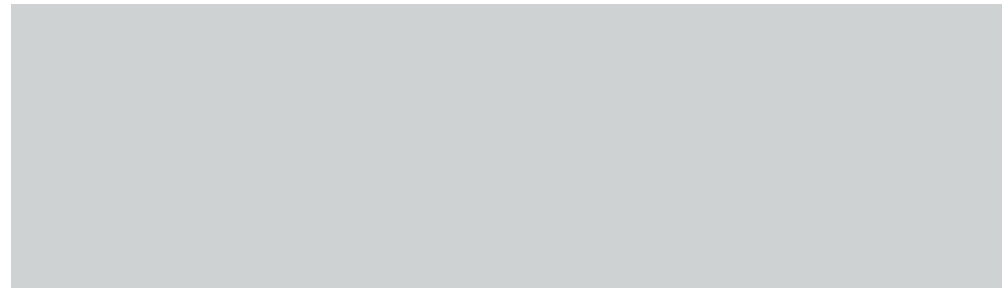

ANTA SPESSORE 20 mm
20 mm thick door



ANTA LIGHT

LIGHT DOOR

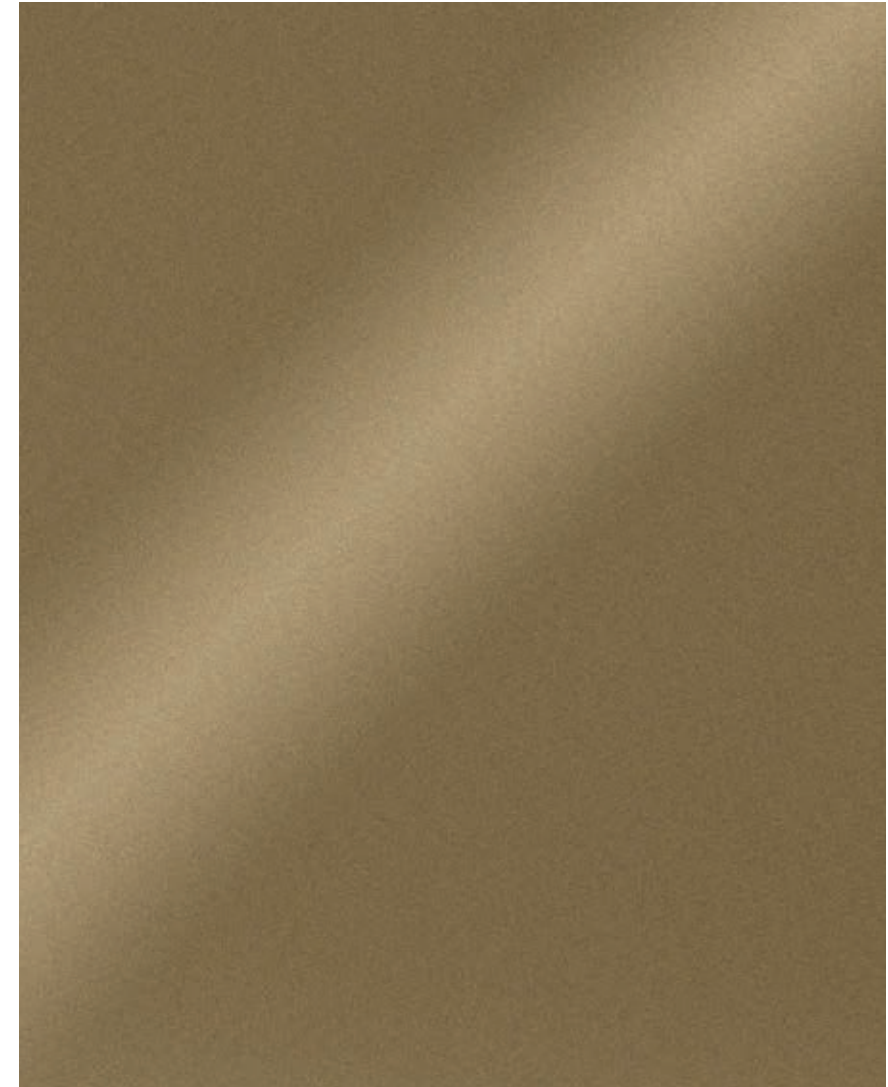
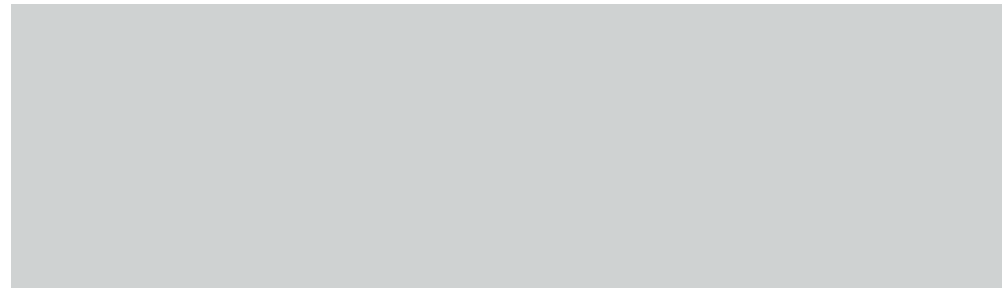

ANTA SPESSORE 10 mm
10 mm thick door



FINITURE

FINISHES

LACCATI NCS

LACQUERED NCS

FINITURE ANTA LIGHT
Finishes for Light door

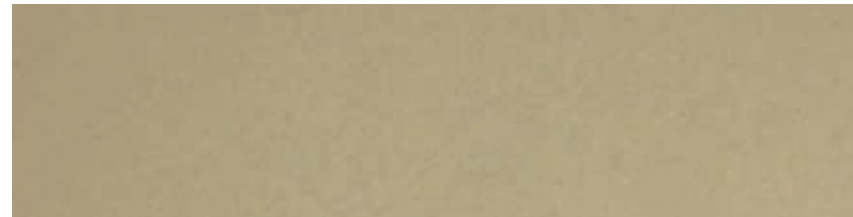

CHAMPAGNE

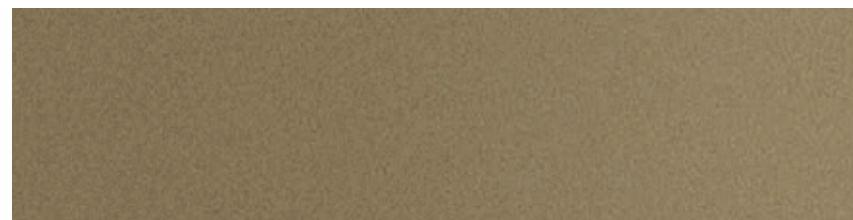

BRONZATO

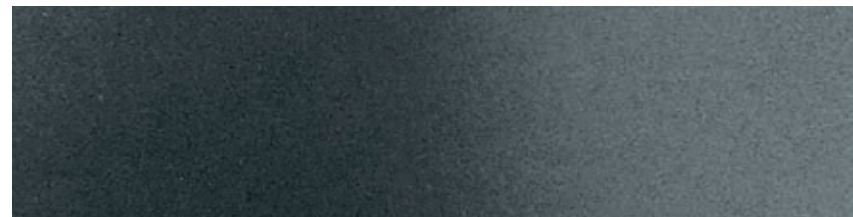

ANTRACITE

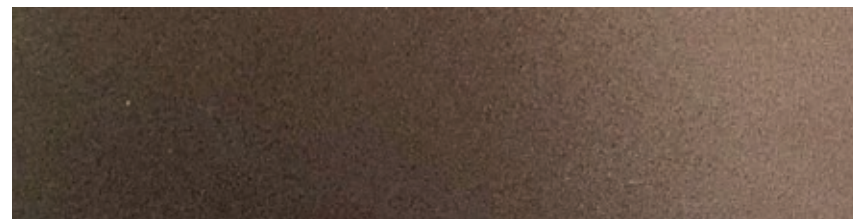

RAMATO

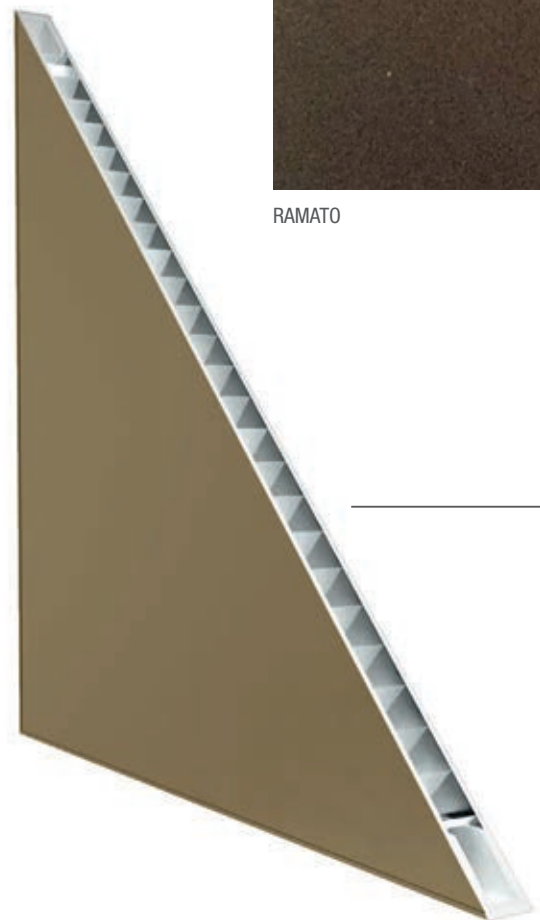

SEZIONE ANTA / Door section

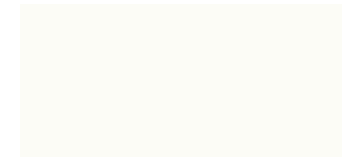

BIANCO - NCS 0300-N



PERLA - NCS 1500-N



RUGIADA - NCS 2502-Y



COLOMBA - NCS 3500-N



SETA - NCS 1502-G50Y

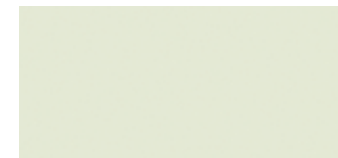

NEBBIA - NCS 1005-G70Y



FUMO - NCS 2005-G60Y



POLVERE - NCS 3005-G20Y

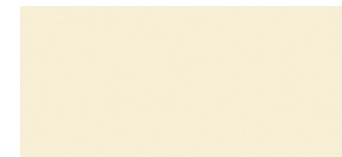

CORDA - NCS 0804-Y30R

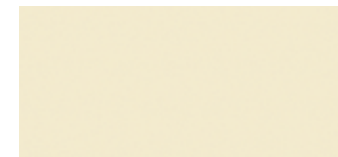

CANAPA - NCS 0907-Y10R



AVORIO - NCS 1505-Y30R



SABBIA - NCS 2030-G90Y



SENAPE - NCS 3005-Y50R



TORTORA - NCS 4005-Y20R



OMBRA - NCS 5005-G80Y



DAINO - NCS 5502-Y



PIOGGIA - NCS 6000-N



CASTORO - NCS 5005-Y20R



CENERE - NCS 5005-Y50R



CAPPUCCINO - NCS 4010-G90Y



CAFFÈ - NCS 7010-Y70R



VERDE - NCS S6010-B70G



BOSCO - NCS 7010-B30G



PETROLIO - NCS 7010-B10G



NUVOVA - NCS 4020-B10G



PIETRA - NCS 4005-B20G



CIPRIA - S3010Y-50R



TERRA - NCS 6030-Y90R



RUBINO - NCS 2570-R



PIOMBO - NCS 6502-G



CARBONE - NCS 7502-Y



CORTECCIA - NCS 8000-N



GRAFITE - NCS 7502-B



NERO - NCS 9000N

OLDLINE ARREDAMENTI SRL

Via Cal Larga, 56
31010 Mareno di Piave
Treviso - Italy

T. +39 0438 492506

F. +39 0438 492549

oldline@oldline.it

www.oldline.it